

Direct conversion RX		SDR
Sampling detector		
Chaudar LZ1AQ	Rev 2.0 14.8.2007	Page # 2

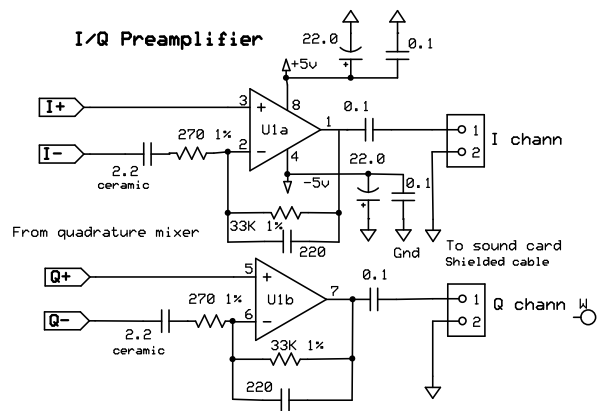

U1 is low noise opamp as OPA2228, TS462, TL072  
 Gain = 122, Fresp 0.3 - 22 KHz

Direct conversion RX SDR		
Audio pre-amplifiers		
Chaudar LZ1AQ	Rev 2.0 14.8.2007	Page # 2

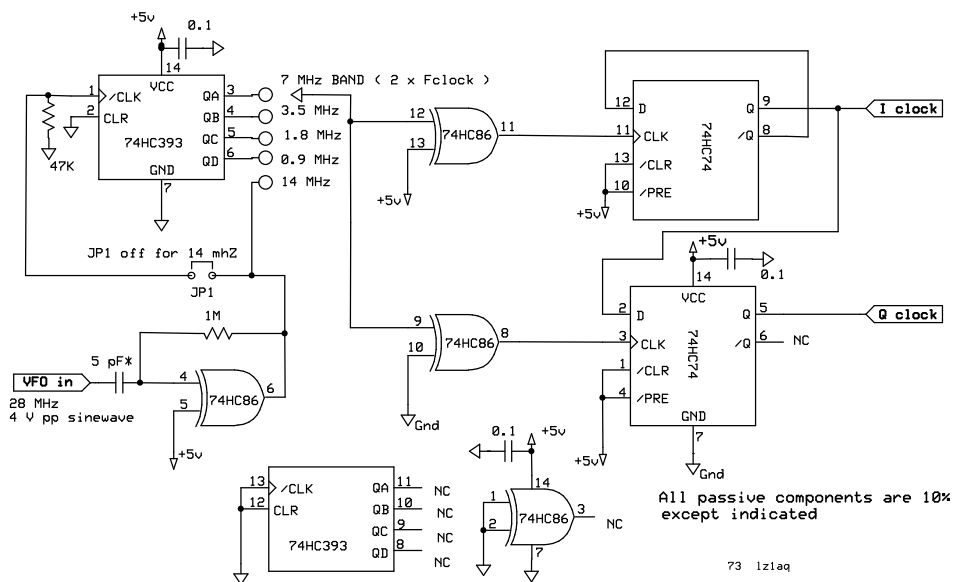

Direct conversion RX SDR	
<b>4 Band Quadrature Generator</b>	
Chavdar LZ1AQ	Rev 2.0
	Page # 3

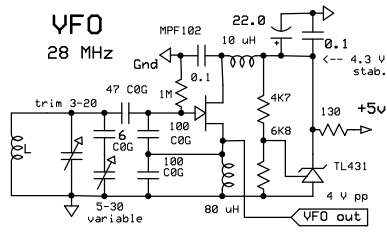

Direct conversion RX SDR	
VFO 28 MHz	
Chaudar LZ1AQ	Rev 2.0
Page # 3	

### Convertor +5 to -5 volts

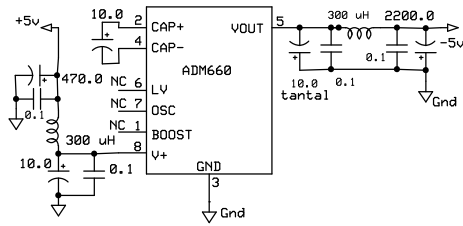

Direct conversion RX SDR	
<b>Convertor +5 to -5 volts</b>	
Chavdar LZ1AQ	Rev 2.0
	Page # 3

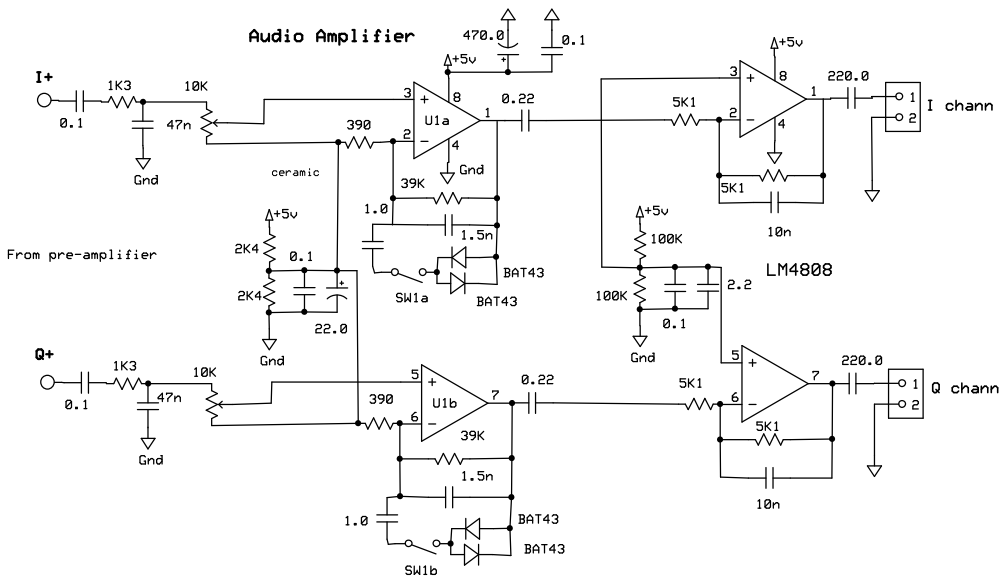

U1 is low noise opamp as TS462, TL072  
 Gain = 100 Fresp 0.3 - 2.8KHz

Direct conversion RX		SDR
Audio amplifier		
Chavdar LZ1AQ	Rev 2.0 14.8.2007	Page # 2